

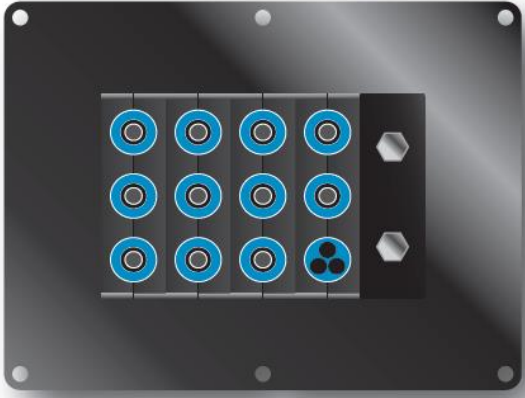

## PRODUCT CATALOGUE

Cable and Pipe Sealing

### Wall Pass Through Equipment DG-K, DG-S, DG-SY, DG-SD and DG-SK



TLC Engineering Wall Pass Through Equipment (WPT) has been designed for sealing of RF cables and pipes passing through wall and floor penetrations in buildings, shelters (containers) and steel constructions. It provides sealing at IP 67.

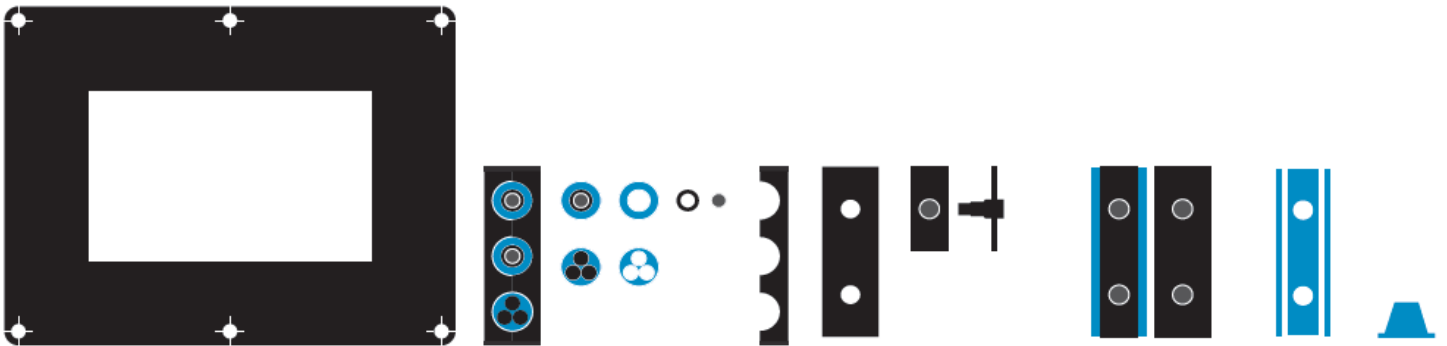

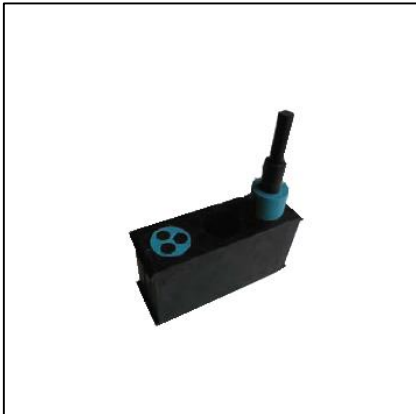

### Features

WPTE is produced from special rubber, which is highly resistant to harsh climatic conditions. Standards of 75 up to 90 shore of this rubber results in excellent sealing and provides IP 67 protection.

Cable Modules come in two different diameters (7/8' and 1/2') and with their specially designed frame they allow perfect fitting of cables for the commonly used diameters in GSM business.

Different sized modules can be used within the same frame to achieve the desired settings.

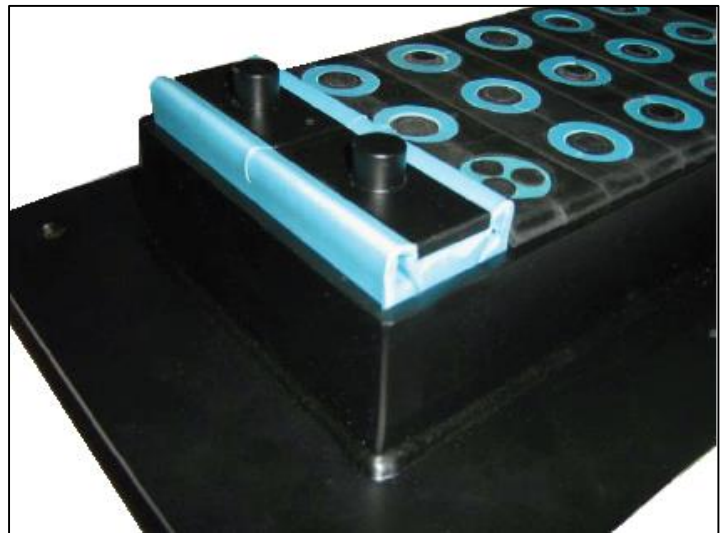

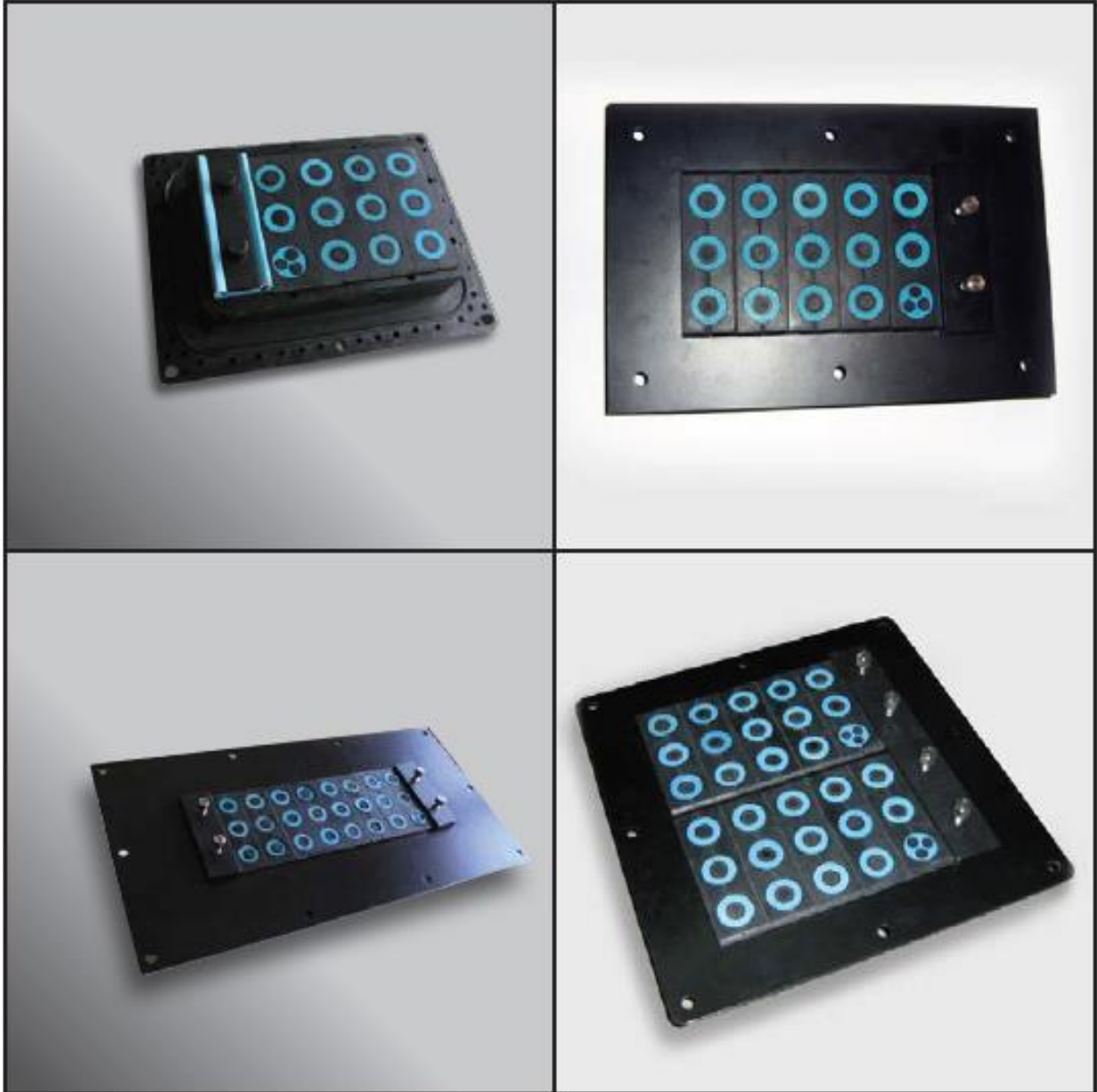

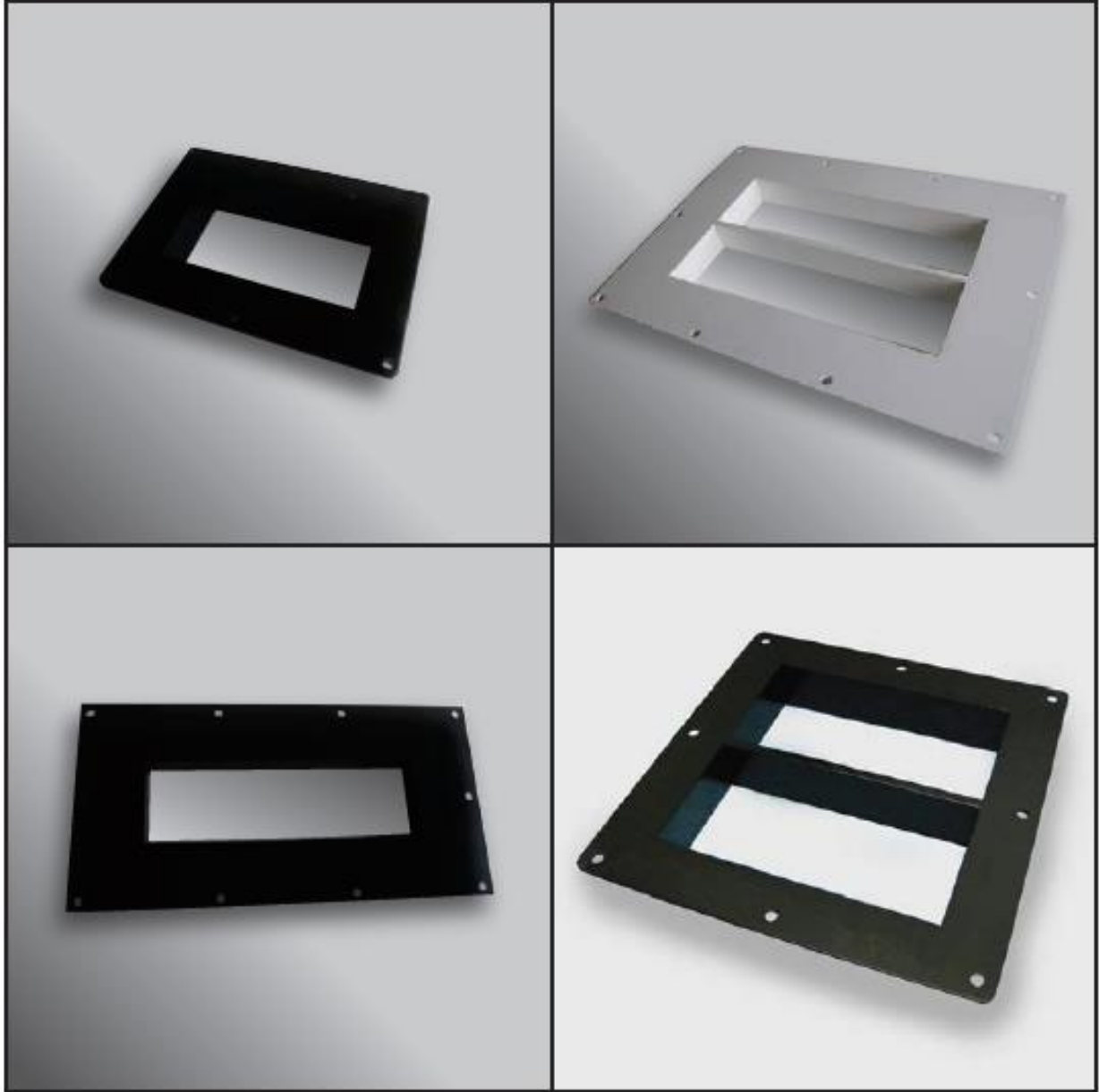

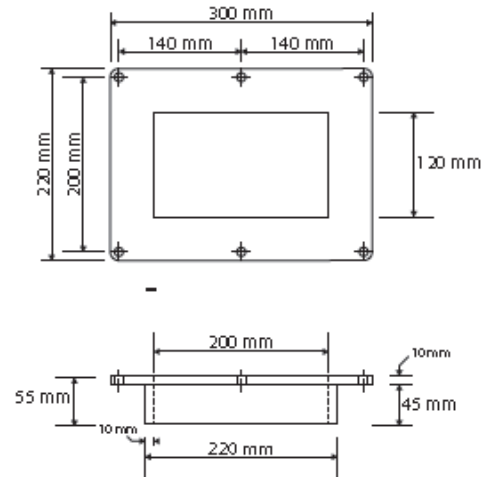

## Wall Pass Through Equipment, [DG-K/12, DG-K/15] Rubber Coated Steel Frame

Article/Code	Feeder Holes	Int. Frame Size	Ext. Frame Size	Wall Opening Size HxW	~ Weight (gr)
<b>DG-K/12</b>	12x7/8" or 1/2", 3x1F	120x200 mm	220x300 mm	 150x230 mm	5,550
031221-00					



Article/Code	Feeder Holes	Int. Frame Size	Ext. Frame Size	Wall Opening Size HxW	~ Weight (gr)
<b>DG-K/15</b>	15x7/8" or 1/2", 3x1F	120x240 mm	220x340 mm	 150x270 mm	6,250
031521-00					

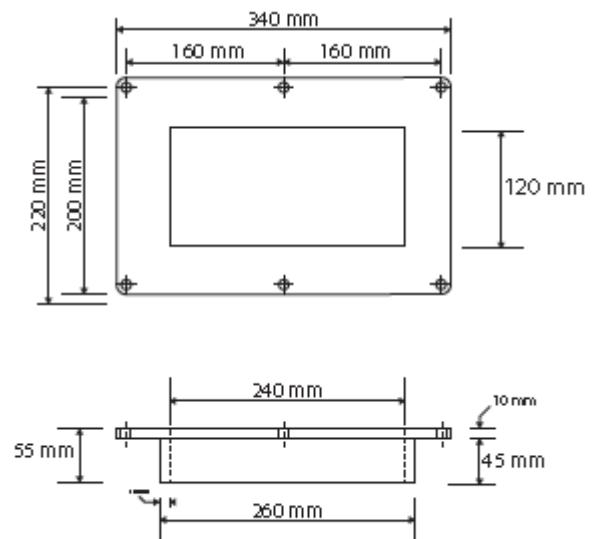
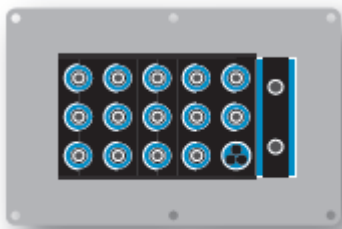

## Wall Pass Through Equipment, [DG-S/12, DG-S/15, DG-S/18]

Article/Code	Feeder Holes	Int. Frame Size	Ext. Frame Size	Wall Opening Size HxW	~ Weight (gr)
<b>DG-S/12</b>	12x7/8" or 1/2", 3x1F	120x200 mm	240x320 mm	 140x220 mm	5,420

031211-00

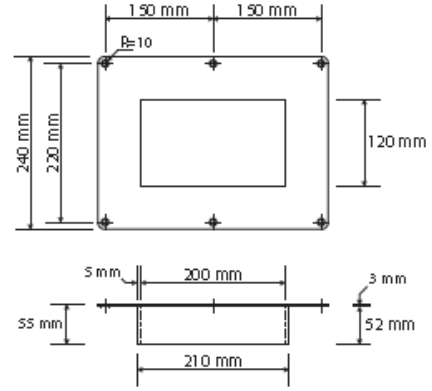

Article/Code	Feeder Holes	Int. Frame Size	Ext. Frame Size	Wall Opening Size HxW	~ Weight (gr)
<b>DG-S/15</b>	15x7/8" or 1/2", 3x1F	120x200 mm	240x360 mm	 140x260 mm	5,870

031511-00

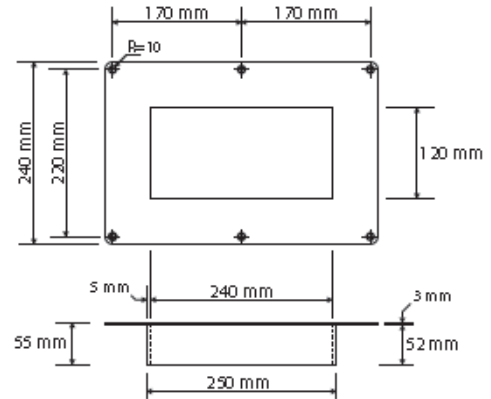
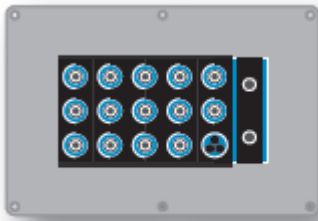

Article/Code	Feeder Holes	Int. Frame Size	Ext. Frame Size	Wall Opening Size HxW	~ Weight (gr)
<b>DG-S/18</b>	18x7/8" or 1/2", 3x1F	120x280 mm	240x400 mm	 140x300 mm	6,320

031811-00

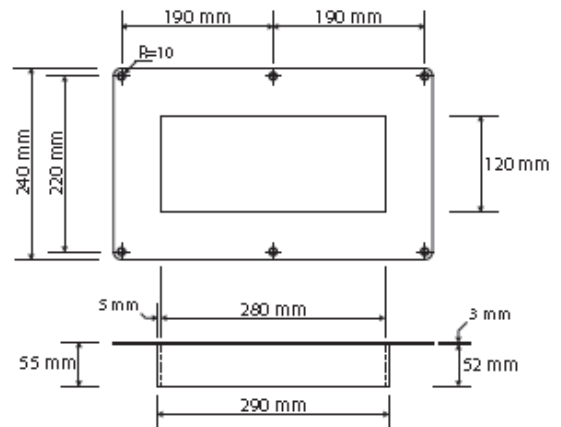
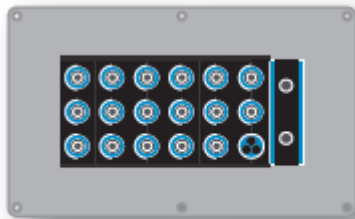

## Wall Pass Through Equipment, [DG-SY/24, DG-SY/30, DG-SY/36]

Article/Code	Feeder Holes	Int. Frame Size	Ext. Frame Size	Wall Opening Size HxW	~ Weight (gr)
<b>DG-SY/24</b>	24x7/8" or 1/2", 6x1F	2x [120x200 mm]	240x525 mm	 130x425 mm	10,180

032421-00

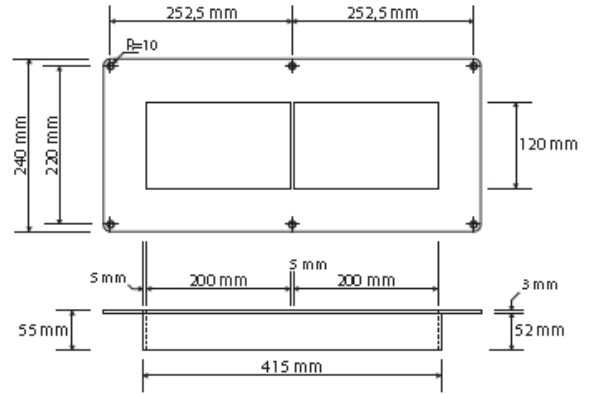
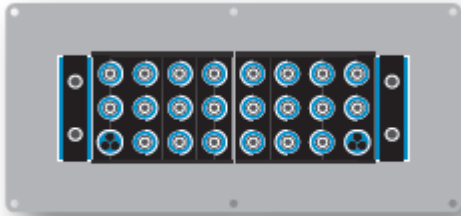

Article/Code	Feeder Holes	Int. Frame Size	Ext. Frame Size	Wall Opening Size HxW	~ Weight (gr)
<b>DG-SY/30</b>	30x7/8" or 1/2", 6x1F	2x [120x240 mm]	240x605 mm	 140x505 mm	11,180

033021-01

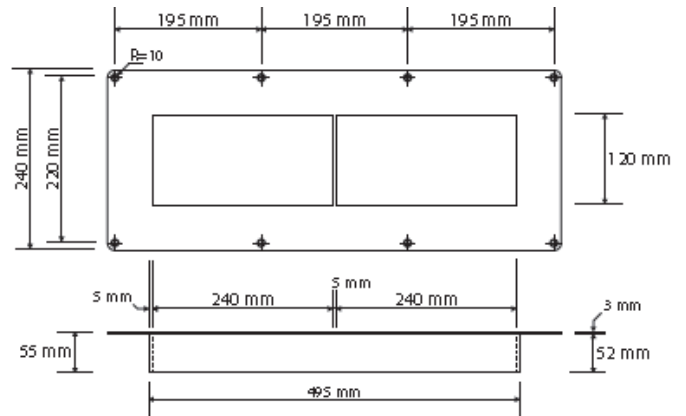
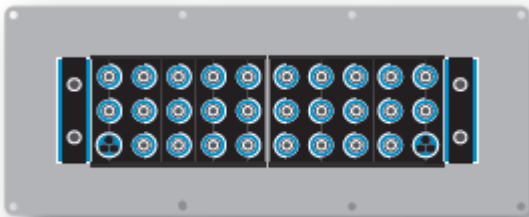

Article/Code	Feeder Holes	Int. Frame Size	Ext. Frame Size	Wall Opening Size HxW	~ Weight (gr)
<b>DG-SY/36</b>	36x7/8" or 1/2", 6x1F	2x [120x280 mm]	240x685 mm	 140x585 mm	11,970

033621-01

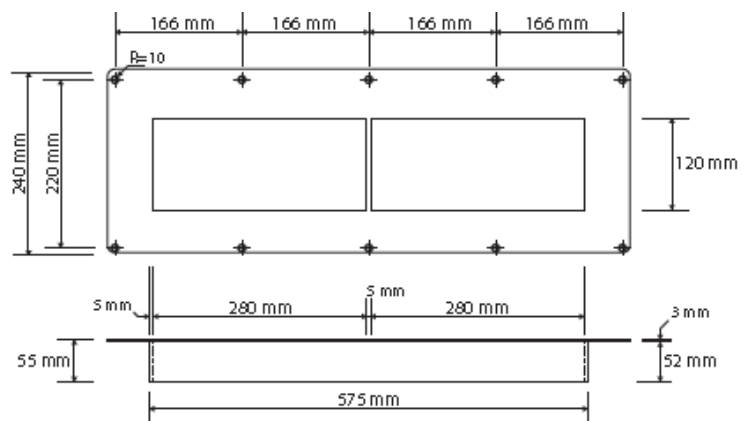
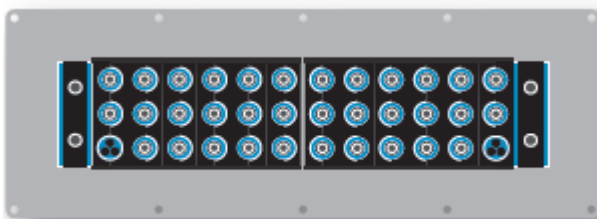



## Wall Pass Through Equipment, [DG-SD/24, DG-SD/30]

Article/Code	Feeder Holes	Int. Frame Size	Ext. Frame Size	Wall Opening Size HxW	~ Weight (gr)
<b>DG-SD/24</b>	24x7/8" or 1/2", 6x1F	2x [120x200 mm]	370x320 mm	 270x220 mm	10,000
032421-02					

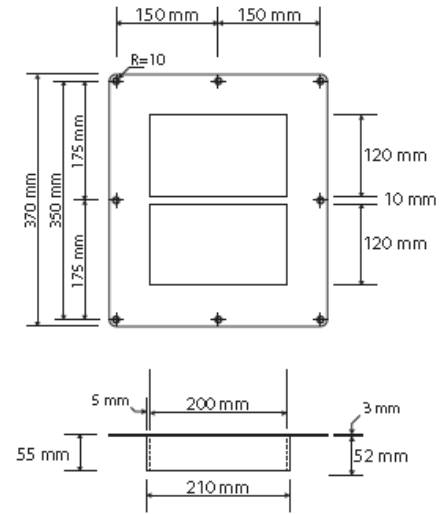
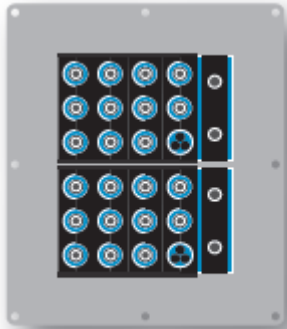

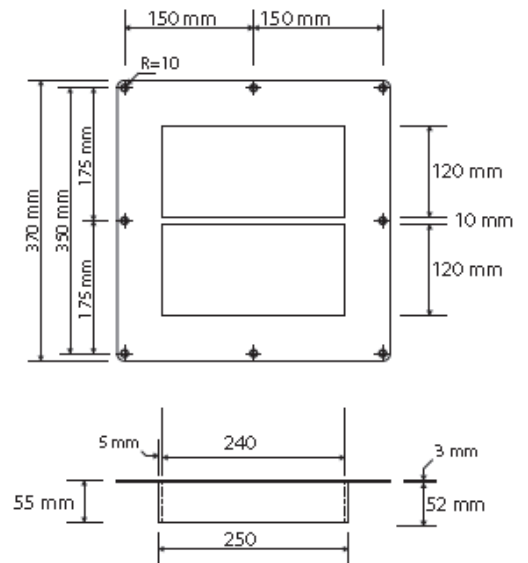
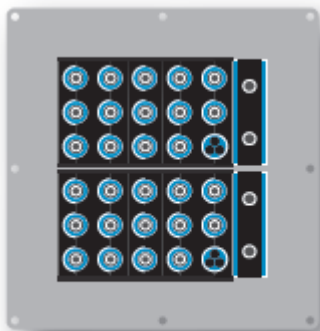

Article/Code	Feeder Holes	Int. Frame Size	Ext. Frame Size	Wall Opening Size HxW	~ Weight (gr)
<b>DG-SD/30</b>	30x7/8" or 1/2", 6x1F	2x [120x240 mm]	370x360 mm	 270x260 mm	10,790
033021-02					

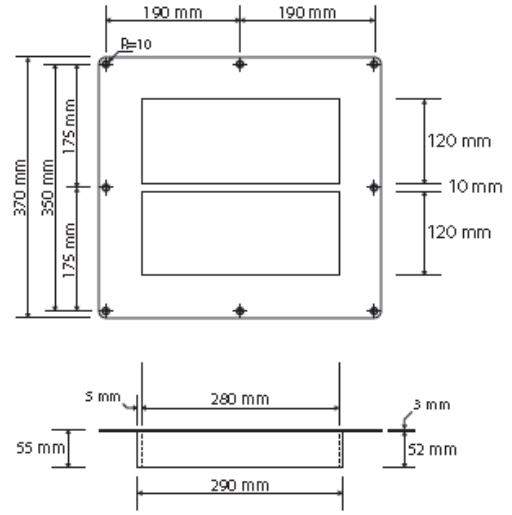
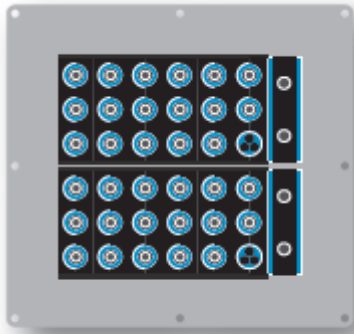

## Wall Pass Through Equipment, [DG-SD/36, DG-SD/48]

Article/Code	Feeder Holes	Int. Frame Size	Ext. Frame Size	Wall Opening Size HxW	~ Weight (gr)
<b>DG-SD/36</b>	36x7/8" or 1/2", 6x1F	2x [120x280 mm]	370x400 mm	 270x300 mm	11,570
033621-02					



Article/Code	Feeder Holes	Int. Frame Size	Ext. Frame Size	Wall Opening Size HxW	~ Weight (gr)
<b>DG-SD/48</b>	48x7/8" or 1/2", 12x1F	4x [120x200 mm]	370x525 mm	 270x425 mm	18,980
034841-03					

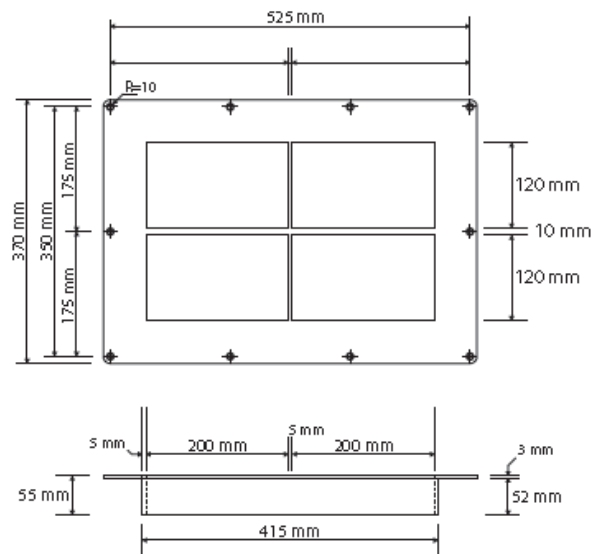
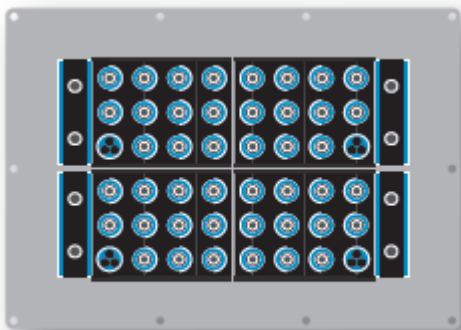

## Air Conditioner Pipe Sealing Aparatus

Article/Code	Feeder Holes	Int. Frame Size	Ext. Frame Size	Wall Opening Size HxW	~ Weight (gr)
<b>APS/2</b>					
050221-02					



Article/Code	Feeder Holes	Int. Frame Size	Ext. Frame Size	Wall Opening Size HxW	~ Weight (gr)
<b>APS/1</b>					
050121-02					



## Mains & Earthing Cable Entrance

Article/Code	Feeder Holes	Int. Frame Size	Ext. Frame Size	Wall Opening Size HxW	~ Weight (gr)
<b>MEC/01</b>					
300121-15					



**TLC Office**

Küçükbakkalköy Mah.  
Dudullu Cad. No:23-25  
Brandium Residence  
R2 Blok Kat:26 Daire: 249  
Ataşehir - İstanbul  
Turkey  
[www.tlc.com.tr](http://www.tlc.com.tr)

**TLC Factory**

Meclis Mah.  
Perpim Sanayi Sitesi  
A Blok No:86  
Sancaktepe - İstanbul  
Turkey  
[www.tlc.com.tr](http://www.tlc.com.tr)